



Cultura del vetro

MARCEL WANDERS ECHO



COLLECTION 2020



Cultura del vetro

MARCEL
WANDERS
ECHO



ECHO SHOWCASE 02 • ECHO CUPBOARD 14 • POP TV MIRROR 28



ECHO
showcase

Struttura champagne,
vetro extralight fuso.
Champagne structure,
fused extralight glass.



ECHO
showcase

Struttura champagne,
vetro semi-riflettente.
Champagne structure,
semi-reflecting glass.



ECHO
showcase



Struttura champagne,
vetro semi-riflettente.
Champagne structure,
semi-reflecting glass.

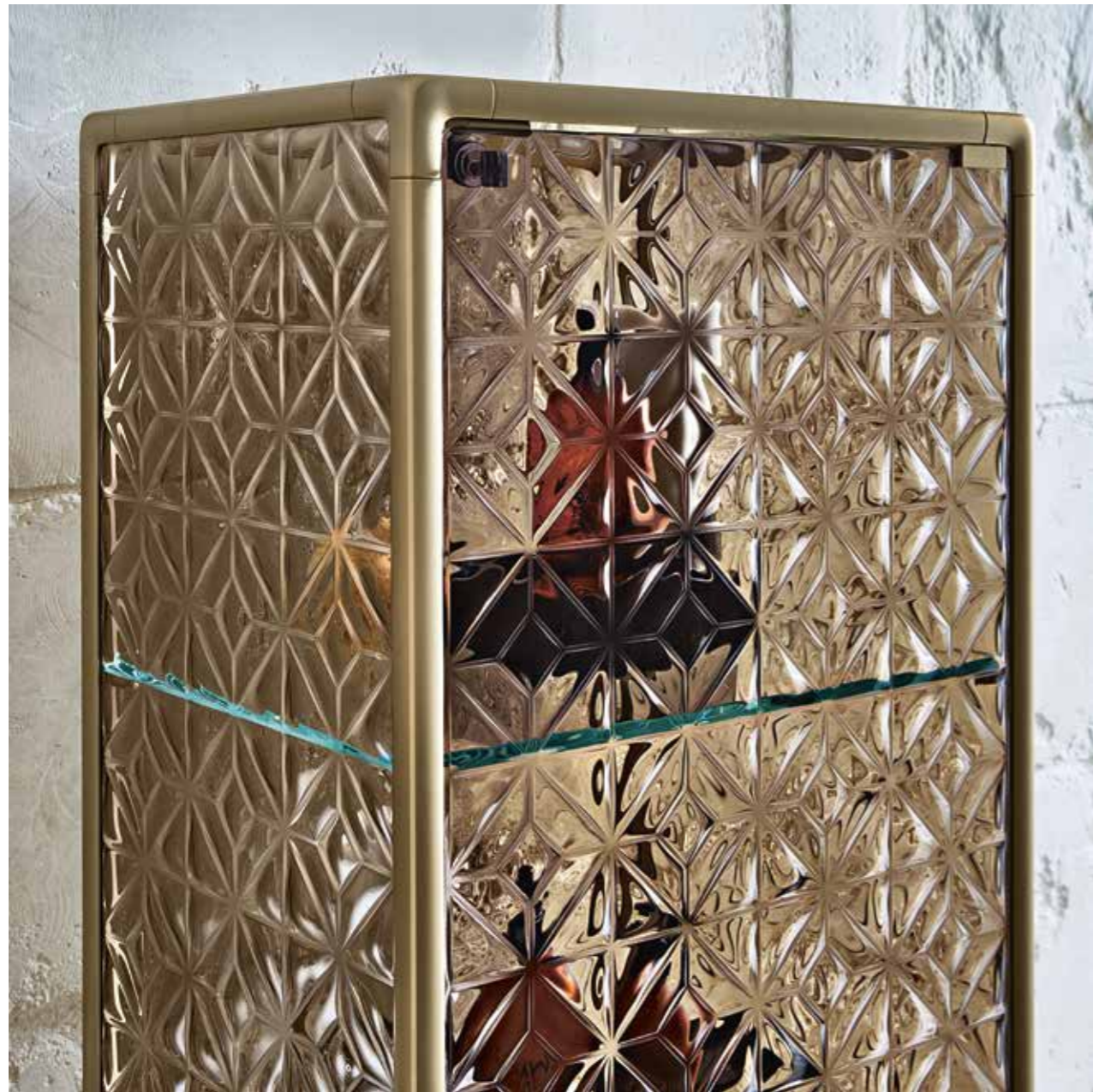

Struttura champagne,
vetro bronzo fuso.
Champagne structure,
fused bronze glass.



ECHO
showcase



Struttura grigio vulcano,
vetro fumè fuso.
Vulcan grey structure,
fused smoked glass.



ECHO
showcase

Struttura grigio vulcano,
vetro fumè fuso.
Vulcan grey structure,
fused smoked glass.



ECHO
cupboard

Struttura grigio vulcano,
ante in vetro extralight fuso
e retroverniciato grigio vulcano.
Vulcan grey structure,
fused extralight glass doors,
vulcan grey back painted.



ECHO
cupboard

Struttura grigio vulcano,
ante in vetro extralight fuso
e retroverniciato grigio vulcano.
Vulcan grey structure,
fused extralight glass doors,
vulcan grey back painted.





ECHO
cupboard

Struttura bianco opaco,
ante in vetro bronzo fuso
e retroargentato.
Matt white structure,
fused and back-silvered
bronze glass doors.







Struttura bianco opaco,
ante in vetro extralight fuso
e retroargentato.
Matt white structure,
fused and back-silvered
extralight glass doors.

POP TV
mirror





**T E C H -
N I C A L
D A T A
S H E E T S**

ECHO

showcase



Vetrina con struttura in alluminio verniciato, disponibile nelle finiture champagne metallizzato e grigio vulcano. Base in vetro extralight da 6 mm temperato retroverniciato in tinta con la struttura; corpo vetrina ed ante in vetro extralight, fumé o bronzo da 6 mm fuso a gran fuoco e temperato; ripiani in vetro extralight da 8 mm temperato. La vetrina è disponibile anche in vetro piano (non fuso) ed in vetro semiriflettente. Sistema di illuminazione a LED integrato nei montanti frontali della struttura (opzionale).

Vitrine avec profils en aluminium vernis, disponibles dans les finitions métalliques champagne et gris volcan. Base en verre trempé extra light de 6 mm, verni dessous pour s'adapter aux profils ; structure et portes de la vitrine en verre trempé extra light, fumé ou bronzé de 6 mm ; étagères en verre trempé extra light de 8 mm. La vitrine est également disponible en verre plat (pas en fusion) et en verre semi-réfléchissant. Système d'éclairage LED intégré dans les montants avant de la structure (optionnel).

Showcase with varnished aluminium structure, available in metalized champagne or vulcan grey finishes. Base in 6 mm thick tempered and back-painted extralight glass of the same profiles color; relevant glass structure and doors in 6 mm thick extralight, smoked or bronze tempered and fused glass; inner shelves in 8 mm thick extralight tempered glass. The showcase is also available in float (non fused) glass and in semi reflecting glass. LED lighting system integrated in the frontal pillars of the structure (optional).

Vitrine mit lackierten Aluminiumprofilen, in den Varianten Champagner-Metallic und Vulkangrau erhältlich. Sockel aus 6 mm extralight, gehärtetem Glas in den selben Farbtönen. Vitrine und Türen aus 6 mm verschmolzenem und gehärtetem Glas in den Varianten extralight Glas oder Rauchglas oder Bronzeglas. Interne Fachböden aus 8 mm extralight, gehärtetem Glas. Die Vitrine ist auch in den folgenden Varianten erhältlich: aus glattem Glas (nicht verschmolzen) oder aus halbreflektierendem Glas. In die vorderen Pfosten der Struktur integriertes LED-Beleuchtungssystem (optional).

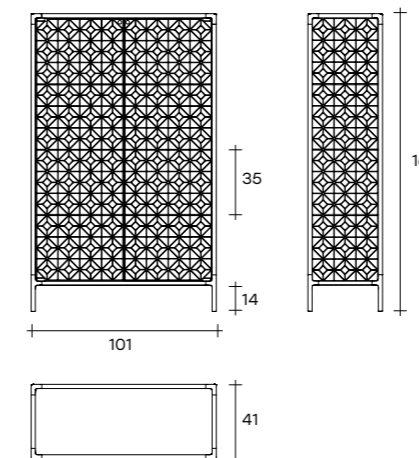

101 x 41 x 163 cm
 39 3/4" x 16 1/8" x 64 3/16"
 53 x 41 x 175 cm
 20 7/8" x 16 1/8" x 68 7/8"

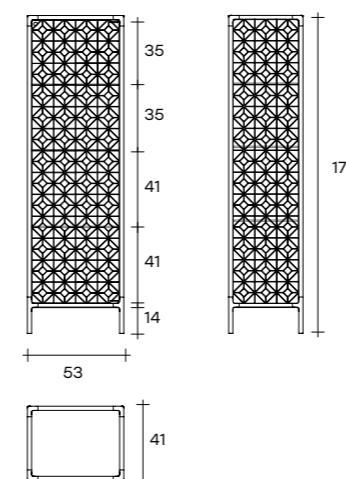

Struttura in finitura champagne _ Champagne finish structure



vetro extralight extralight glass vetro semi-riflettente semi-reflecting glass vetro extralight fuso fused extralight glass vetro bronzo fuso fused bronze glass

Struttura in finitura grigio vulcano _ Vulcan grey finish structure



vetro extralight extralight glass vetro fumé smoked glass vetro fumé fuso fused smoked glass



ECHO

cupboard



Struttura in finitura grigio vulcano _ Vulcan grey finish structure

Struttura in finitura bianco opaco _ Matt white finish structure



ante in vetro extralight fuso e retroverniciato grigio vulcano
fused extralight glass doors, vulcan grey back-painted



ante in vetro extralight fuso e retroargentato
fused and back-silvered extralight glass doors



ante in vetro bronzo fuso e retroargentato
fused and back-silvered bronze glass doors



ante in vetro extralight fuso e retroverniciato bianco
fused extralight glass doors, white back-painted



ante in vetro extralight fuso e retroargentato
fused and back-silvered extralight glass doors



ante in vetro bronzo fuso e retroargentato
fused and back-silvered bronze glass doors

Madia con struttura in legno laccato bianco opaco oppure grigio vulcano. Ante in vetro da 6 mm fuso e temperato, disponibili nelle seguenti finiture: vetro extralight retroverniciato bianco, grigio vulcano, oppure retroargentato; vetro bronzo retroargentato. Ripiani interni in vetro fumè da 8 mm temperato.

Cupboard with wooden lacquered matt white or vulcan grey structure. Doors in 6 mm thick fused and tempered glass, available in the following finishes: extralight back-painted white, vulcan grey or back-silvered glass; back-silvered bronze glass. Inner shelves in 8 mm thick tempered smoke glass.

Buffet avec structure en bois laqué blanc mat ou gris volcan. Portes en verre en fusion et trempé de 6 mm, disponibles dans les finitions suivantes : verre extra light verni dessous blanc, gris volcan ou argenté ; verre bronze argenté dessous. Etagères intérieures en verre fumé trempé de 8 mm.

Sideboard mit Struktur aus matt weiß oder vulkangrau lackiertem Holz. Türen aus 6 mm verschmolzenem und gehärtetem Glas, in den folgenden Varianten erhältlich: extralight Glas weiß oder vulkangrau lackiert, oder versilbertes extralight Glas, oder versilbertes Bronzeglas. Interne Fachböden aus 8 mm starkem, gehärtetem Rauchglas.

199 x 47 x 74 cm
78 3/8" x 18 1/2" x 29 1/8"
265 x 47 x 74 cm
104 5/16" x 18 1/2" x 29 1/8"

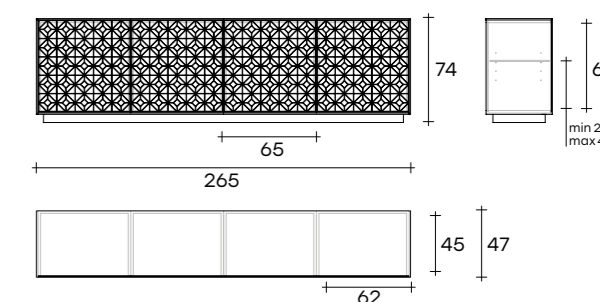
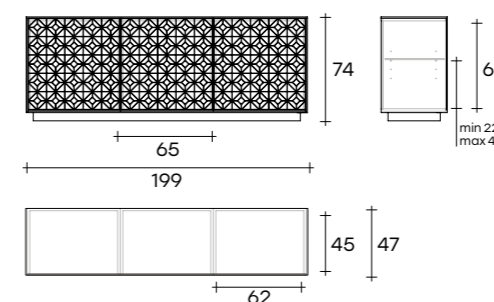

POP TV

mirror

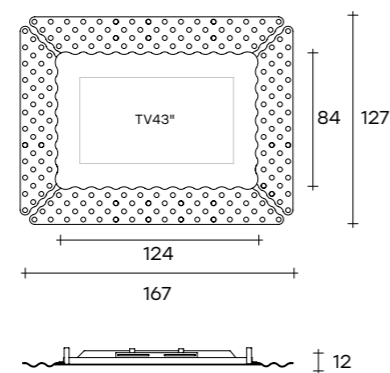
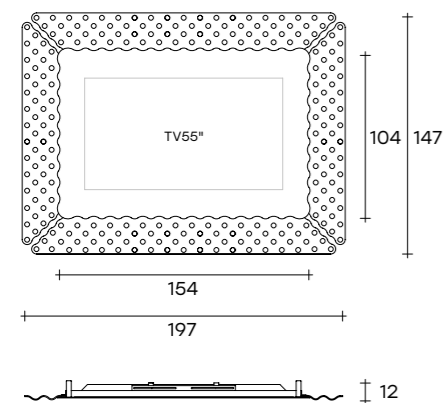

167 x 12 x 127 cm (TV 43")
65 3/4" x 4 3/4" x 50"
197 x 12 x 147 cm (TV 55")
77 9/16" x 4 3/4" x 57 7/8"

Specchio da parete con televisore incorporato. Specchio centrale in vetro semiriflettente da 5 mm retrovernicciato nero. Cornice formata da 4 elementi in vetro fumè da 6 mm fuso a gran fuoco e retroargentato. Telaio in metallo verniciato nero opaco.

Wall mirror with TV included. Central mirror in semi-reflecting black back-painted glass 5 mm thick. Frame composed by 4 fused and back-silvered smoke glass elements 6 mm thick. Rear frame in matt black painted metal.

Miroir à accrocher avec télévision intégrée. Miroir central en verre semi-réfléchissant de 5 mm, verni dessous noir. Cadre composé de 4 éléments en verre fumé de 6 mm, en fusion et argenté dessous. Cadre arrière en métal verni en noir mat.

Spiegel mit eingebautem TV-Gerät. Flacher Spiegel aus 5 mm halbreflektierendem Glas, schwarz hinterlackiert. Rahmen aus 4 einzelnen Elementen aus 6 mm Rauchglas verschmolzen und versilbert.

art direction

acanto comunicazione
(carlo piazzesi)

graphic design and layout
acanto comunicazione

photography and postproduction
studio leon

styling
conti | marchetti studio

marketing project
daniele livi

coordination and logistics
lorenzo marzoli

selections
olimpia visual plan

print and packaging
grapho 5

september 2020

credits

AMINI CARPET
FFERRONE DESIGN
FIAMMETTA V
HK LIVING
L'OPIFICIO
MANI BY BRITTA HERRMANN
MARTINELLI LUCE
NAHOOR
ZAFFERANO

thanks to

LUDOVICA + ROBERTO PALOMBA

Fiam Italia

Via Ancona 1/b
61010 Tavullia (PU)
Italy

T: +39 0721 20051
F: +39 0721 202432
info@fiamitalia.it

#fiamitalia

follow us on



fiamitalia.it

“L’idea alla base di questi contenitori è stata quella di progettare una superficie che si estendesse fisicamente alle persone. La superficie in rilievo conferisce al prodotto un estremo senso di profondità. Con motivi ripetuti di forme in vetro molto diverse su tutti i lati, la bellezza è apprezzabile da ogni punto di vista. La sperimentazione è essenziale per il nostro processo di progettazione e lavorare a fianco di FIAM ci ispira sempre a creare qualcosa di nuovo. I loro innovativi processi di lavorazione del vetro ci consentono di progettare prodotti lussuosi capaci di generare un forte senso di illusione attraverso l’uso forme inedite. Queste collezioni sono la dimostrazione di come con FIAM siamo in grado di ottenere eleganza grazie all’utilizzo del vetro e scoprire così nuovi lidi in cui approdare con questo magico materiale”.

“L’idée derrière ces conteneurs était de concevoir une surface qui s’étendrait physiquement aux personnes. La surface gaufrée donne au produit une sensation de profondeur extrême. Avec des motifs répétés de formes de verre très différentes sur tous les côtés, la beauté est appréciée à tout point de vue. L’expérimentation est essentielle à notre processus de conception et travailler au côté de FIAM nous inspire toujours pour créer quelque chose de nouveau. Leurs processus innovants de fabrication du verre nous permettent de concevoir des produits luxueux qui génèrent un fort sentiment d’illusion grâce à l’utilisation de nouvelles formes. Ces collections montrent comment, grâce à FIAM, nous pouvons atteindre l’élégance par l’utilisation du verre et ainsi découvrir de nouveaux rivages où atterrir avec ce matériau magique”.



“The idea behind these cabinets was to design a surface that would physically extend out to people. The relief surface gives the piece depth and meaning. With repeating patterns of very different shapes in glass on all sides, the beauty endures from every angle. Experimentation is essential to our process and working alongside FIAM inspires us to create something new. Their innovative glass processes allow us to design luxurious pieces in which we can use shapes to create a sense of illusion. These series are the next example of how with FIAM, we are able to push elegance with glass and discover new places it can take us”.

“Die Idee hinter diesen Vitrinen und Sideboard war es, eine Oberfläche zu entwerfen, die sich physisch auf Menschen ausdehnt. Die gaufrierte Bearbeitung verleiht dem Produkt eine extrem tiefe Haptik. Mit Dekor aus unterschiedlichen Formen und auf allen Seiten wird Schönheit in jeder Hinsicht geschätzt. Das Experimentieren ist für unseren Designprozess unerlässlich, und die Zusammenarbeit mit FIAM ITALIA inspiriert uns immer wieder dazu, etwas Neues zu schaffen. Ihre innovativen Glasherstellungsverfahren ermöglichen es uns, Produkte zu entwerfen, die durch die Verwendung neuer Formen ein starkes Gefühl der Illusion erzeugen. Der Kollektion zeigt, wie wir dank FIAM ITALIA durch den Einsatz von Glas Eleganz erreichen und so neue "Ufer" entdecken können, auf denen wir mit diesem magischen Material landen können”.

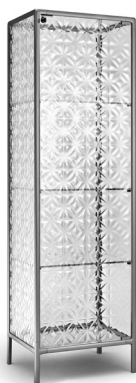

echo

DESIGN MARCEL
WANDERS STUDIO

modello registrato
registered model

portata su ogni piano: 20 kg
portata sul top: 30 kg
load capacity on each shelf: 20 kg
load capacity on the top: 30 kg

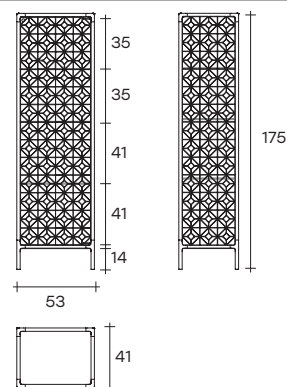

Vetrina con struttura in alluminio verniciato, disponibile nelle finiture champagne metallizzato e grigio vulcano. Base in vetro extralight da 6 mm temperato retroverniciato in tinta con la struttura; corpo vetrina ed ante in vetro extralight, fumé o bronzo da 6 mm fuso a gran fuoco e temperato; ripiani in vetro extralight da 8 mm temperato. La vetrina è disponibile anche in vetro

piano (non fuso) ed in vetro semiriflettente. Sistema di illuminazione a LED integrato nei montanti frontali della struttura (opzionale)*.

Showcase with varnished aluminium profiles, available in metalized champagne or vulcan grey finishes. Base in 6 mm thick tempered and back lacquered extralight glass

of the same profiles color; relevant glass structure and doors in 6 mm thick extralight, smoke or bronze tempered and fused glass; inner shelves in 8 mm thick extralight tempered glass. The showcase is also available in float (non fused) glass and in semi reflecting glass. LED lighting system integrated in the structure frontal pillars (optional)*.

* Prodotto marcato CE, disponibile solo per mercato europeo.

* CE certification, only for European countries available.

| dimensioni L, P, H dimensions L, W, H (cm) | COD./CODE | L | P/W | H | peso netto net weight (kg) | peso lordo gross weight (kg) | volume imballo package volume (m ³) |
|--|---------------------|----|-----|-----|----------------------------------|------------------------------------|---|
| Vetrina con struttura champagne ; corpo vetrina ed ante in vetro extralight . Showcase with champagne profiles; relevant glass structure and doors in extralight glass . | ECV53/CH-VX | 53 | 41 | 175 | 64 | 99 | 0,685 |
| Vetrina con struttura champagne ; corpo vetrina ed ante in vetro semi-riflettente . Showcase with champagne profiles; relevant glass structure and doors in semi-reflecting glass . | ECV53/CH-SCC | 53 | 41 | 175 | 64 | 99 | 0,685 |
| Vetrina con struttura champagne ; corpo vetrina ed ante in vetro extralight fuso . Showcase with champagne profiles; relevant glass structure and doors in fused extralight glass . | ECV53/CH-VXF | 53 | 41 | 175 | 64 | 99 | 0,685 |
| Vetrina con struttura champagne ; corpo vetrina ed ante in vetro bronzo fuso . Showcase with champagne profiles; relevant glass structure and doors in fused bronze glass . | ECV53/CH-VBF | 53 | 41 | 175 | 64 | 99 | 0,685 |
| Vetrina con struttura grigio vulcano ; corpo vetrina ed ante in vetro extralight . Showcase with vulcan grey profiles; relevant glass structure and doors in extralight glass . | ECV53/VU-VX | 53 | 41 | 175 | 64 | 99 | 0,685 |
| Vetrina con struttura grigio vulcano ; corpo vetrina ed ante in vetro fumè . Showcase with vulcan grey profiles; relevant glass structure and doors in smoke glass . | ECV53/VU-VF | 53 | 41 | 175 | 64 | 99 | 0,685 |
| Vetrina con struttura grigio vulcano ; corpo vetrina ed ante in vetro fumè fuso . Showcase with vulcan grey profiles; relevant glass structure and doors in fused smoke glass . | ECV53/VU-VFF | 53 | 41 | 175 | 64 | 99 | 0,685 |

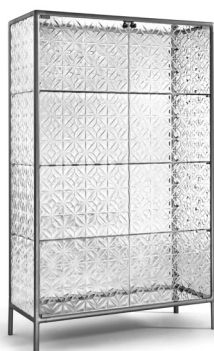

echo

DESIGN MARCEL
WANDERS STUDIO

modello registrato
registered model

portata su ogni piano: 20 kg
portata sul top: 30 kg
load capacity on each shelf: 20 kg
load capacity on the top: 30 kg

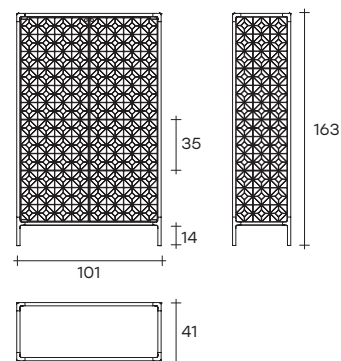

dimensioni L, P, H
dimensions L, W, H
(cm)

| | COD./CODE | L | P/W | H | peso netto <i>net weight</i> (kg) | peso lordo <i>gross weight</i> (kg) | volume imballo <i>package volume</i> (m ³) |
|--|----------------------|-----|-----|-----|---|---|--|
| Vetrina con struttura champagne ; corpo vetrina ed ante in vetro extralight . <i>Showcase with champagne profiles; relevant glass structure and doors in extralight glass.</i> | ECV101/CH-VX | 101 | 41 | 163 | 98 | 144 | 1,12 |
| Vetrina con struttura champagne ; corpo vetrina ed ante in vetro semi-riflettente . <i>Showcase with champagne profiles; relevant glass structure and doors in semi-reflecting glass.</i> | ECV101/CH-SCC | 101 | 41 | 163 | 98 | 144 | 1,12 |
| Vetrina con struttura champagne ; corpo vetrina ed ante in vetro extralight fuso . <i>Showcase with champagne profiles; relevant glass structure and doors in fused extralight glass.</i> | ECV101/CH-VXF | 101 | 41 | 163 | 98 | 144 | 1,12 |
| Vetrina con struttura champagne ; corpo vetrina ed ante in vetro bronzo fuso . <i>Showcase with champagne profiles; relevant glass structure and doors in fused bronze glass.</i> | ECV101/CH-VBF | 101 | 41 | 163 | 98 | 144 | 1,12 |
| Vetrina con struttura grigio vulcano ; corpo vetrina ed ante in vetro extralight . <i>Showcase with vulcan grey profiles; relevant glass structure and doors in extralight glass.</i> | ECV101/VU-VX | 101 | 41 | 163 | 98 | 144 | 1,12 |
| Vetrina con struttura grigio vulcano ; corpo vetrina ed ante in vetro fumè . <i>Showcase with vulcan grey profiles; relevant glass structure and doors in smoke glass.</i> | ECV101/VU-VF | 101 | 41 | 163 | 98 | 144 | 1,12 |
| Vetrina con struttura grigio vulcano ; corpo vetrina ed ante in vetro fumè fuso . <i>Showcase with vulcan grey profiles; relevant glass structure and doors in fused smoke glass.</i> | ECV101/VU-VFF | 101 | 41 | 163 | 98 | 144 | 1,12 |

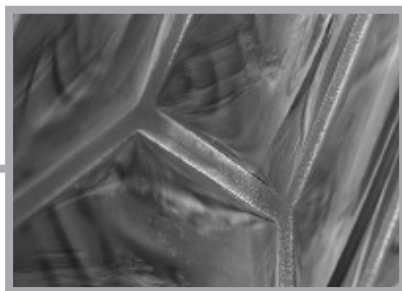

La forgiatura a caldo può generare leggere irregolarità e/o piccoli aloni chiari in prossimità dei decori, segni distintivi del processo di fusione ad alta temperatura che ne garantiscono l'artigianalità. Non possono quindi essere oggetto di contestazione.

Heat forging can generate slight irregularities and/or small white marks in the proximity of the decorations, distinguishing marks of the high-temperature fusion process that guarantee craftsmanship. They cannot therefore be contested.

**FINITURE
FINISHES****Struttura in finitura champagne
Champagne finish structure**

vetro extralight
extralight glass

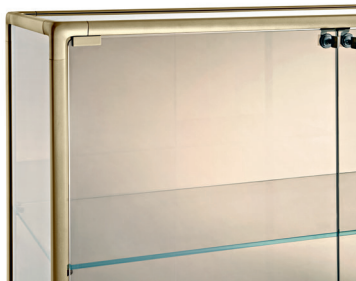

vetro semi-riflettente
semi-reflecting glass



vetro extralight fuso
fused extralight glass



vetro bronzo fuso
fused bronze glass

**Struttura in finitura grigio vulcano
Vulcan grey finish structure**

vetro extralight
extralight glass



vetro fumé
smoked glass



vetro fumé fuso
fused smoked glass